

# CHAPTER 7: HEATING, VENTILATION, AIR CONDITIONING (HVAC)

---

When thinking about energy efficiency, one of the most important decisions to be made regarding a new home is the type of heating and cooling system to install. Equally critical to consider is the selection of the heating and cooling contractor. The operating efficiency of a system depends as much on proper installation as it does on the performance rating of the equipment.

Improper design and improper installation of the HVAC system have negative impacts on personal comfort and on energy bills. Improper design and installation of a HVAC system can dramatically degrade the quality of air in a home. Poorly designed and poorly installed ducts can create dangerous conditions that may reduce comfort, degrade indoor air quality, or even threaten the health of the homeowners.

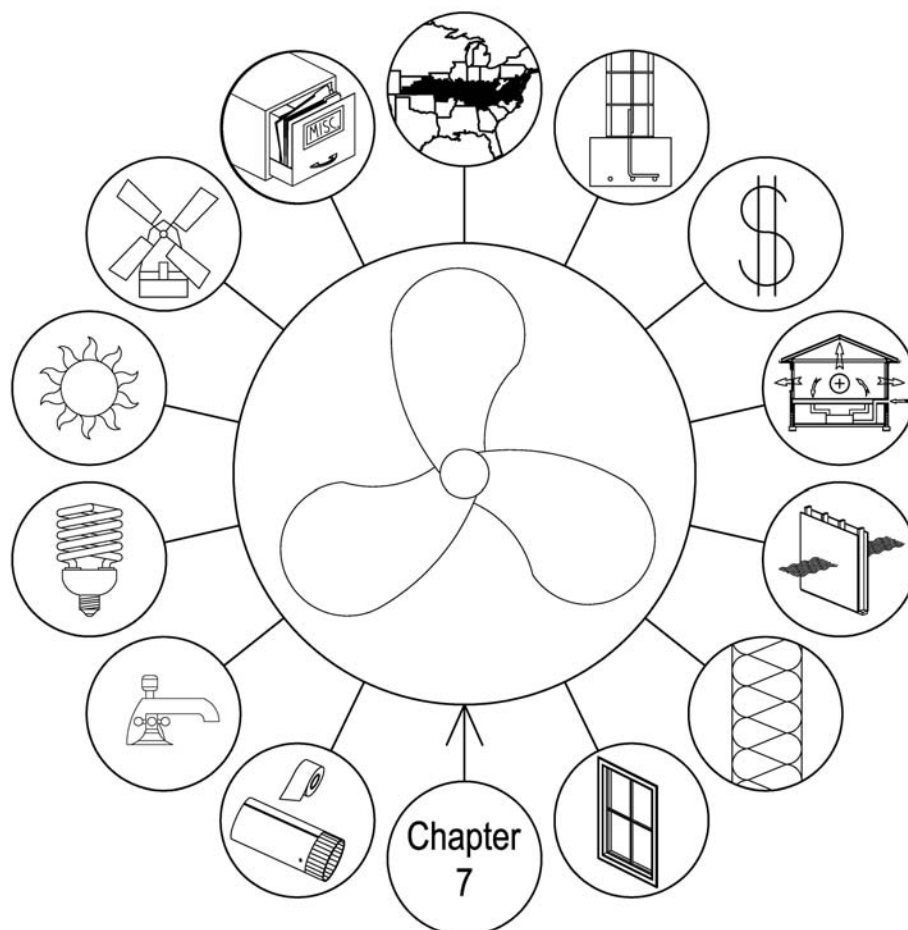



## TYPES OF HEATING SYSTEMS

Keys to obtaining design efficiency of a system in the field include:

- Sizing the system for the specific heating and cooling load of the home being built;
- Proper selection and proper installation of controls;
- Correctly charging the unit with the proper amount of refrigerant;
- Sizing and designing the layout of the ductwork or piping for maximizing energy efficiency; and
- Insulating and sealing all ductwork.

Two types of heating systems are most common in a new home: forced-air or radiant, with forced-air being used in the majority of the homes. The heat source is either a furnace, which burns a gas, or an electric heat pump. Furnaces are generally installed with central air conditioners. Heat pumps provide both heating and cooling. Some heating systems have an integrated water heating system.

### FORCED-AIR SYSTEM COMPONENTS

Most new homes have forced-air heating and cooling systems. These systems use a central furnace plus an air conditioner, or a heat pump. Figure 7-1 shows all the components of a forced-air system. In a typical system, several of these components are combined into one unit. Forced-air systems utilize a series of ducts to distribute the conditioned heated or cooled air throughout the home. A blower, located in a unit called an air handler, forces the conditioned air through the ducts. In many residential systems, the blower is integral with the furnace enclosure.

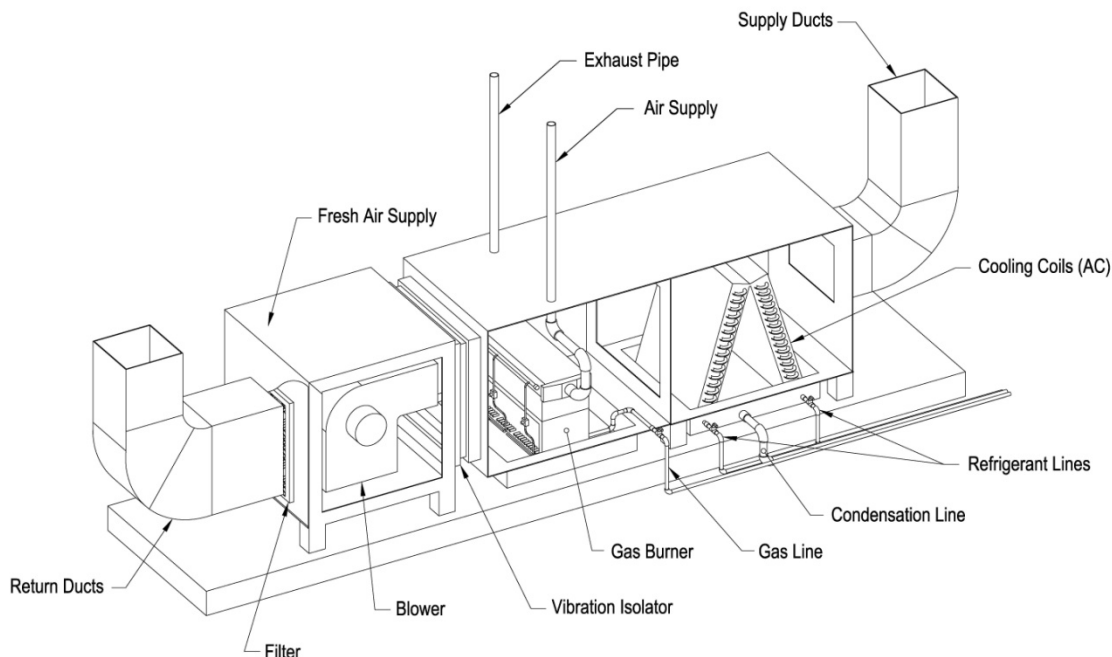

Figure 7 – 1 Components of Horizontal Flow Forced-Air Systems



Most homes in Kentucky have a choice of the following approaches for central, forced-air systems; fuel-fired furnaces with electric air conditioning units, electric heat pumps or a dual fuel system that combines both a fuel-fired furnace with an electric heat pump. The best system for each home depends on the cost and efficiency of the equipment, annual energy use, and the local price and availability of energy sources. In most homes, either type of system, if designed and installed properly, will economically deliver personal comfort.

---

## RADIANT HEATING SYSTEMS

Radiant heating systems typically combine a central boiler, water heater or heat pump water heater with piping, to transport steam or hot water into the living area. Heating is delivered to the rooms in the home via radiators or radiant floor systems, such as radiant slabs or underfloor piping.

Advantages of radiant heating systems include:

- Quieter operation than heating systems that use forced-air blowers.
- Increased personal comfort at lower air temperatures. The higher radiant temperatures of the radiators or floors allow people to feel warmer at lower air temperatures. Some homeowners, with radiant heating systems, report being comfortable at room air temperatures of 60°F.
- Better zoning of heat delivered to each room.
- Increased comfort from the heat. Many homeowners, with radiant heating systems, find that the heating is more comfortable.

Disadvantages of radiant heating systems include:

- Higher installation costs. Radiant systems typically cost 40% to 60% more to install than comparable forced-air heating systems.
- No provision for cooling the home. The cost of a radiant heating system, combined with central cooling, would be difficult to justify economically. Some designers of two-story homes have specified radiant heating systems on the bottom floor and forced-air heating and cooling on the second floor.
- No filtering of the air. Since the air is not cycled between the system and the house, there is no filtering of the air.
- Difficulty in locating parts. A choice of dealers may be limited.

---

## HEAT PUMP EQUIPMENT

Heat pumps are designed to move heat from one fluid to another. The fluid inside the home is air and the fluid outside is either air (air-source), or water (geothermal). In the summer, heat from the inside air is moved to the outside fluid. In the winter, heat is taken from the outside fluid and moved to the inside air.

---

### AIR-SOURCE HEAT PUMPS

The most common type of heat pump is the air-source heat pump. Most heat pumps operate at least twice as efficiently as conventional electric resistance heating systems in Climate Zone 4. They have typical lifetimes of 15 years, compared to 20 years for most furnaces.



Heat pumps use the vapor compression cycle to move heat (see Figure 7-2). A reversing valve allows the heat pump to work automatically in either heating or cooling mode. The heating process is:

1. The compressor (in the outside unit) pressurizes the refrigerant, which is piped inside.
2. The hot gas enters the inside condensing coil. Room air passes over the coil and is heated. The refrigerant cools and condenses.
3. The refrigerant, now a pressurized liquid, flows outside to a throttling valve where it expands to become a cool, low pressure liquid.
4. The outdoor evaporator coil, which serves as the condenser in the cooling process, uses outside air to boil the cold, liquid refrigerant into a gas. This step completes the cycle.
5. If the outdoor air is so cold that the heat pump cannot adequately heat the home, electric resistance strip heaters usually provide supplemental heating.

Periodically in winter, the heat pump must switch to a "defrost cycle," which melts any ice that has formed on the outdoor coil. Packaged systems and room units use the above components in a single box.

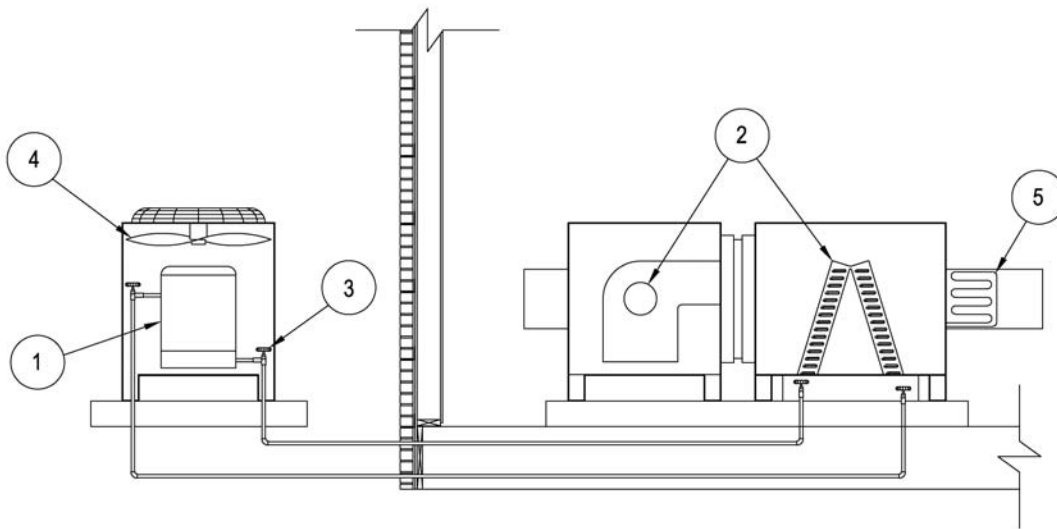

Figure 7 – 2 Air Conditioner Vapor Compression Cycle

At outside temperatures of 25°F to 35°F, a properly sized heat pump can no longer meet the entire heating load of the home. The temperature at which a properly sized heat pump can no longer meet the heating load is called the balance point. To provide supplemental backup heat, many builders use electric resistance coils called strip heaters. The strip heaters, located in the air-handling unit, are much more

expensive to operate than the heat pump itself. The strip heaters should not be oversized, as they can drive up the peak load requirements of the local electric utility.

A staged, heat pump thermostat can be used in concert with multistage strip heaters to minimize strip heat operation. To overcome this problem, some houses use a dual-fuel system that heats the home with natural gas or propane when temperatures drop below the balance point.

Air-source heat pumps should have outdoor thermostats, which prevent operation of the strip heaters at temperatures above 35°F or 40°F. Many mechanical and energy codes require controls to prevent strip heater operation during weather when the heat pump alone can provide adequate heating.

The proper airflow across the coil is essential for the efficient operation of a heat pump. During installation, the airflow rate must be checked to ensure that it meets the manufacturer's recommendations.

## AIR-SOURCE HEAT PUMP EFFICIENCY

---

The heating efficiency of a heat pump is measured by its Heating Season Performance Factor (HSPF), which is the ratio of heat provided in Btu per hour to watts of energy used. This factor considers the losses when the equipment starts up and stops, as well as the energy lost during the defrost cycle.

New heat pumps manufactured after 2005 are required to have an HSPF of at least 7.7. Typical values for the HSPF are 7.7 for minimum efficiency, 8.0 for medium efficiency, and 8.2 for high efficiency. Variable speed heat pumps have HSPF ratings as high as 9.0, and geothermal heat pumps have HSPFs over 10.0. The HSPF averages the performance of heating equipment for a typical winter in the United States, so the actual efficiency will vary in different climates.

To modify the HSPF for a specific climate, a modeling study was conducted and an equation was developed that modifies the HSPF, based on the local design winter temperature. In colder climates, the HSPF declines and in warmer climates, it increases. In Climate Zone 4, the predicted HSPF is approximately 15% less than the reported HSPF.

## GEOHERMAL HEAT PUMPS

---

Unlike an air-source heat pump, which has an outside air heat exchanger, a geothermal heat pump relies on fluid-filled pipes, buried beneath the earth, as a source of heating in winter and cooling in summer, Figures 7-3, 7-4. In each season, the temperature of the earth is closer to the desired temperature of the home, so less energy is needed to maintain comfort. Eliminating the outside equipment means higher efficiency, less maintenance, greater equipment life, no noise, and no inconvenience of having to mow around that outdoor unit. This is offset by the higher installation cost.

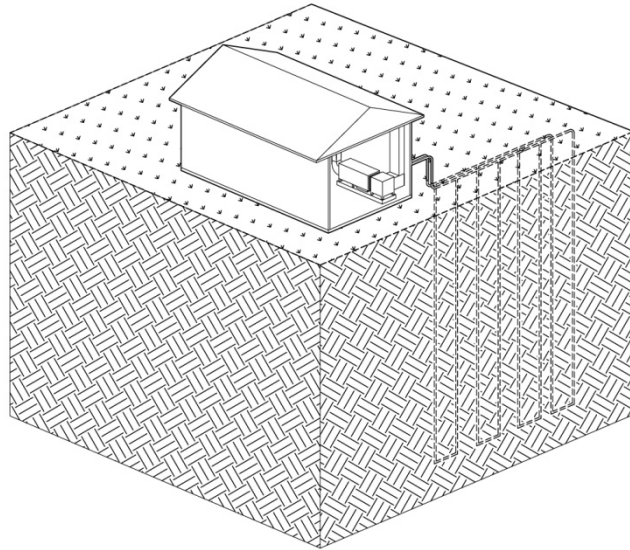

Figure 7 – 3 Deep Well Loop

## Geothermal Heat Pumps

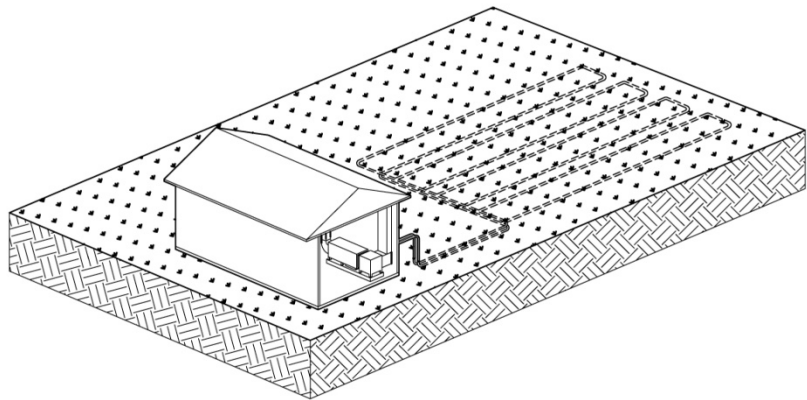

Figure 7 – 4 Shallow Trench Loop

There are several types of closed loop designs for piping:

- In deep well systems, a piping loop extends several hundred feet underground.
- Shallow loops are placed in long trenches, typically about 6 feet deep and several hundred feet long. Coiling the piping into a "slinky" reduces the length requirements.
- For homes located on large private lakes, loops can be installed at the bottom of the lake, which usually decreases the installation costs and may improve performance.

Proper installation of the geothermal loops is essential for high performance and the longevity of the system. Choose only qualified professionals, who have several years experience installing geothermal heat pumps similar to that designed for your home.

Geothermal heat pumps provide longer service than air-source units do. The inside equipment should last as long as any other traditional heating or cooling system. The buried piping usually has a 25-year warranty. Most experts believe that the piping will last even longer because it is made of a durable plastic with heat-sealed connections, and the circulating fluid has an anticorrosive additive.

Geothermal heat pumps cost \$1,300 to \$2,300 more per ton than conventional air-source heat pumps. The actual cost varies according to the difficulty of installing the ground loops as well as the size and features

of the equipment. Because of their high installation cost, these units may not be economical for homes with low heating and cooling needs. However, their lower operating costs, reduced maintenance requirements, and greater comfort may make them attractive to many homeowners.

## GEOHERMAL HEAT PUMP EFFICIENCY

---

The heating efficiency of a geothermal heat pump is measured by the Coefficient of Performance (COP), which measures the number of units of heating or cooling produced by a unit of electricity. The COP is a more direct measure of efficiency than the HSPF and is used for geothermal heat pumps because the water temperature is more constant. Manufacturers of geothermal units provide COPs for different supply water temperatures. If a unit were installed with a COP of 3.0, the system would be operating at about 300% efficiency.

## FURNACE EQUIPMENT

---

Furnaces burn fuels such as natural gas, propane, and fuel oil to produce heat and provide warm, comfortable indoor air during cold weather. Furnaces come in a variety of efficiencies. The comparative economics between heat pumps and furnaces depend on the type of fuel burned, its price, the home's design, and the outdoor climate. Recent energy price increases have improved the economics of more efficient equipment. However, due to the long-term price uncertainty of different forms of energy, it is difficult to compare furnaces with various fuel types and heat pumps.

## FURNACE OPERATION

---

Furnaces require oxygen for combustion and extra air to vent exhaust gases. Most furnaces are non-direct vent units—they use the surrounding air for combustion. Others, known as direct vent or uncoupled furnaces, bring combustion air into the burner area via sealed inlets that extend to outside air.

Direct vent furnaces can be installed within the conditioned area of a home since they do not rely on inside air for safe operation. Non-direct vent furnaces must receive adequate outside air for combustion and exhaust venting. The primary concern with non-direct vent units is that a malfunctioning heater may allow flue gases, which could contain poisonous carbon monoxide, into the area around the furnace. If there are leaks in the return system, or air leaks between the furnace area and living space, carbon monoxide could enter habitable areas and cause severe health problems.

Most new furnaces have forced draft exhaust systems, meaning a blower propels exhaust gases out the flue to the outdoors. Atmospheric furnaces, which have no forced draft fan, are not as common due to federal efficiency requirements. However, some furnace manufacturers have been able to meet the efficiency requirements with atmospheric units. Atmospheric furnaces should be isolated from the conditioned space. Those units located in well ventilated crawl spaces and attics usually have plenty of combustion air and encounter no problem venting exhaust gases to the outside.

However, units located in closets or mechanical rooms inside the home, or in relatively tight crawl spaces and basements, may have problems. Furnace mechanical rooms must be well sealed from the other rooms of the home (see Figure 7-5). The walls, both interior and exterior, should be insulated. Two outside-air ducts sized for the specific furnace should be installed from outside into the room, one opening near the floor and another near the ceiling, or as otherwise specified in your locality's gas code.

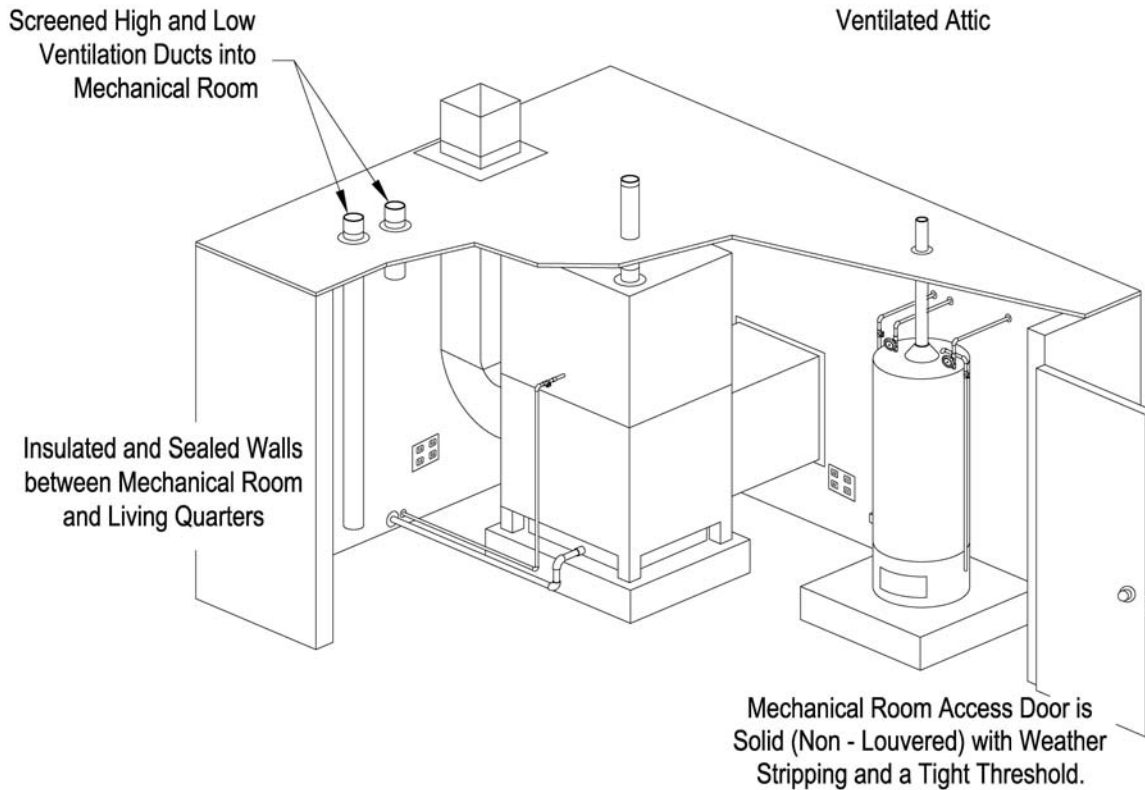

Figure 7 - 5 Sealed Mechanical Room Design

## MEASURES OF EFFICIENCY FOR FURNACES

The efficiency of a gas furnace is measured by the Annual Fuel Utilization Efficiency (AFUE), a rating that takes into consideration losses from pilot lights, start-up, and stopping. The minimum AFUE for most furnaces is now 78%, with efficiencies ranging up to 97% for furnaces with condensing heat exchangers. The AFUE does not consider the unit's electricity use for fans and blowers, which can easily exceed \$50 annually. An AFUE rating of 78% means that for every \$1.00 worth of fuel used by the unit, approximately \$.78 worth of usable heat is produced. The remaining \$.22 worth of energy is lost as waste heat and exhaust up the flue. Efficiency is highest if the furnace operates for longer periods. Oversized units run intermittently and have reduced operating efficiencies.

Furnaces with AFUEs of 78% to 87% include components such as electronic ignitions, efficient heat exchangers, better intake air controls, and induced draft blowers to exhaust combustion products. Models with efficiencies over 90%, commonly called condensing furnaces, include special secondary heat exchangers that actually cool flue gases until they partially condense, so that heat losses up the exhaust pipe are virtually eliminated.





A drain line must be connected to the flue to catch condensate. One advantage of the cooler exhaust gas is that the flue can be made of plastic pipe rather than metal and can be vented horizontally through a side wall.

There are a variety of condensing furnaces available. Some rely primarily on the secondary heat exchanger to increase efficiency, while others, such as the pulse furnace, have revamped the entire combustion process.

A pulse furnace achieves efficiencies over 90% using a spark plug to explode gases, sending a shock wave out an exhaust tailpipe. The wave creates suction to draw in more gas through one-way flapper valves, and the process repeats. Once such a furnace warms up, the spark plug is not needed because the heat of combustion will ignite the next batch of gas. The biggest problem is noise, so make sure the furnace is supplied with a good muffler, and do not install the exhaust pipe where any noise will be annoying.

Because of the wide variety of condensing furnaces on the market, compare prices, warranties, and service. Also, compare the economics carefully with those of moderate efficiency units. Condensing units may have longer paybacks than expected for energy efficient homes due to reduced heating loads. Table 7-1 compares the break-even investment for high efficiency gas furnaces in Code and in ENERGY STAR® homes.

<b>Type of Treatment AFUE 0.95</b>	<b>Energy Savings*(\$/yr) Compared to AFUE 0.80</b>	<b>Break-even Investment‡ (\$)</b>
Code Home	42	477
ENERGY STAR® Home	31	352

\*For a system in Lexington, KY  
‡See Chapter 2 for information on break-even investment.

## ELECTRIC INTEGRATED SYSTEMS

Several products use central heat pumps for water heating, space heating, and air conditioning. These integrated units are available in both air-source and geothermal models. To be a viable choice, integrated systems should:

- Have a proven track record in the field;
- Cost about the same, if not less, than comparable separate heating and hot water systems;
- Provide at least a five-year warranty; and
- Be properly sized for both the heating and hot water load.

Make sure the unit is not substantially more expensive than a separate energy efficient heat pump and electric water heater. Units within \$1,500 may provide favorable economic returns.

## UNVENTED FUEL-FIRED HEATERS

---

Unvented heaters that burn natural gas, propane, kerosene, or other fuels are not recommended. While these devices usually operate without problems, the consequences of a malfunction are life threatening—they can exhaust carbon monoxide directly into household air. Unvented heaters also can cause serious moisture problems inside the home.

Most devices come equipped with alarms designed to detect air quality problems. However, many experts question putting a family at any risk of carbon monoxide poisoning; they see no rationale for bringing these units into a home (Figure 7-6).

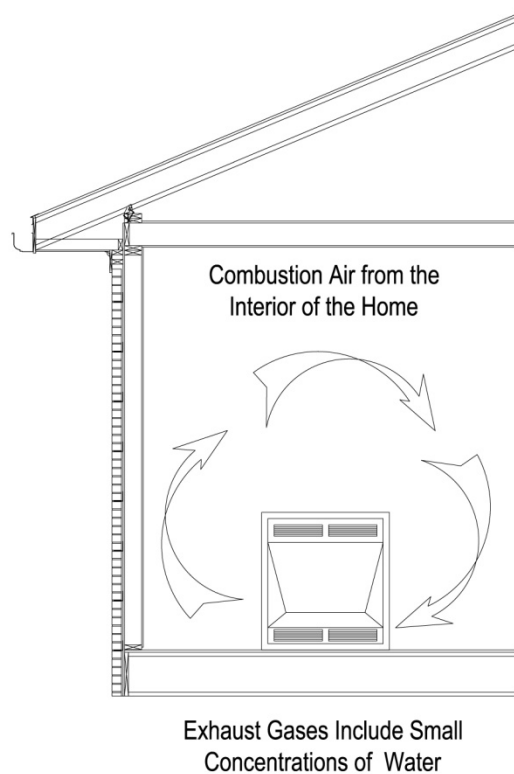

Figure 7-6 Unvented Heater

Examples of unvented units to avoid include:

- Vent-free gas fireplaces. Use sealed combustion, direct vent units instead.
- Room space heaters.

Choose forced draft, direct-vent models instead (Figure 7-7).

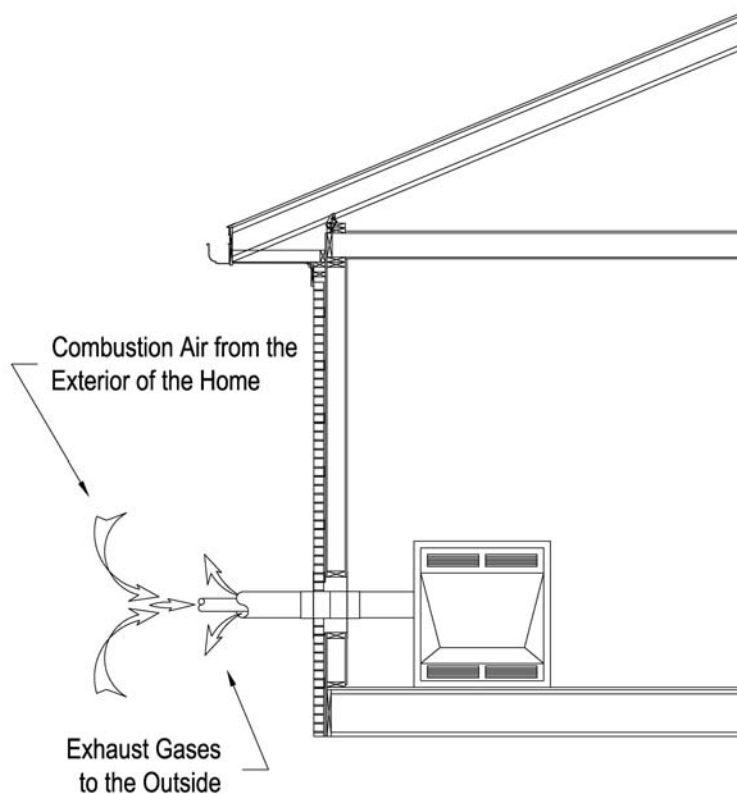

Figure 7-7 Direct Vent Heater

## AIR CONDITIONING

In summer, air conditioners and heat pumps work the same way to provide cooling and dehumidification. They extract heat from inside the home and transfer it outside. Both systems typically use a vapor compression cycle. This cycle circulates a refrigerant, a material that increases in temperature significantly when compressed and cools rapidly when expanded. The exterior portion of a typical air conditioner is called the condensing unit and houses the compressor, the noisy part that uses most of the energy, and the condensing coil.

An air-cooled condensing unit should be kept free from plants and debris that might block the flow of air through the coil or damage the thin fins of the coil. Ideally, the condensing unit should be located in the shade. However, do not block air flow to this unit with dense vegetation, fencing or overhead decking.

The inside mechanical equipment, called the air-handling unit, houses the evaporator coil, the indoor blower, and the expansion, or throttling valve. The controls and ductwork for circulating cooled air to the house complete the system.



## AIR CONDITIONERS

Air conditioners use the vapor compression cycle, a 4-step process (see Figure 7-8).

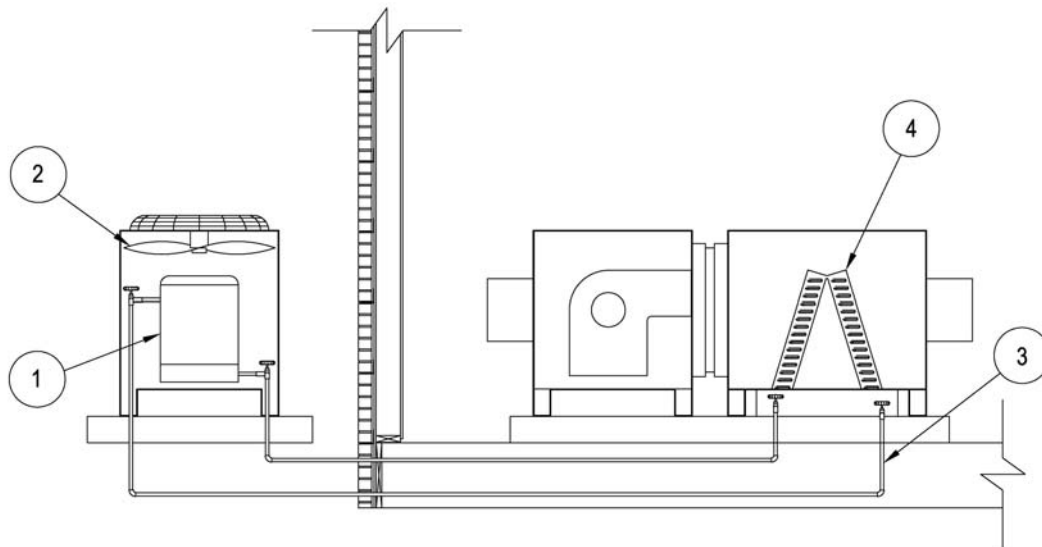

Figure 7-8 Air Conditioner Vapor Compression Cycle

1. The compressor (in the outside unit) pressurizes a gaseous refrigerant. The refrigerant heats up during this process.
2. Fans in the outdoor unit blow air across the heated, pressurized gas in the condensing coil; the refrigerant gas cools and condenses into a liquid.
3. The pressurized liquid is piped inside to the air-handling unit. It enters a throttling or expansion valve, where it expands and cools.
4. The cold liquid circulates through evaporator coils. Inside air is blown across the coils and cooled while the refrigerant warms and evaporates. The cooled air is blown through the ductwork. The refrigerant, now a gas, returns to the outdoor unit where the process repeats.

If units are not providing sufficient dehumidification, the typical homeowner's response is to lower the thermostat setting. Since every degree the thermostat is lowered increases cooling bills 3% to 7%, systems that have nominally high efficiencies, but inadequate dehumidification, may suffer from higher than expected cooling bills. In fact, poorly functioning "high" efficiency systems may actually cost more to operate than a well-designed, moderate efficiency unit.



Make certain that the contractor has used Manual J techniques to size the system so that the air conditioning system meets both sensible and latent (humidity) loads at the manufacturer's claimed efficiency.

## THE SEER RATING

The cooling efficiency of a heat pump or an air conditioner is rated by the Seasonal Energy Efficiency Ratio (SEER), a ratio of the average amount of cooling provided during the cooling season to the amount of electricity used. Current national legislation mandates a minimum SEER 13.0 for most residential air conditioners. Efficiencies of some units can exceed SEER 19.0.

Similar to the HSPF, a modeling study was conducted and an equation was developed that modifies the SEER, based on the local design summer temperature. In warmer climates, the SEER declines. In Climate Zone 4, the predicted SEER is approximately 5% less than the reported SEER.

## VARIABLE SPEED UNITS

The current minimum standard for air conditioners is SEER 13. Higher efficiency air conditioners may be quite economical. Table 7-2 examines the economics of different options for a sample home. In order to increase the overall operating efficiency of an air conditioner or heat pump, multispeed and variable speed compressors have been developed. These compressor units can operate at low or medium speeds when the outdoor temperatures are not extreme. They can achieve a SEER of 15 to 17. The cost of variable speed units is generally about 30% higher than standard units. Variable speed units offer several advantages over standard, single-speed blowers, such as:

- They usually save energy;
- They are quieter, and because they operate fairly continuously, start-up noise is far less (often the most noticeable sound); and
- They dehumidify better. Some units offer a special dehumidification cycle, which is triggered by a humidistat that senses when the humidity levels in the home are too high.

**Table 7-2 Air Conditioner Economics**

Type of Treatment	Energy Savings* (\$/yr)	Break-even Investment‡ (\$)
SEER 14 (3 tons) - compared to SEER 13	20	227
SEER 15 (3 tons) - compared to SEER 14	32	363

\*For a system in Lexington, KY  
 ‡See Chapter 2 for information on break-even investment.



## PROPER INSTALLATION

---

Too often, high efficiency cooling and heating equipment is improperly installed, which can cause it to operate at a substantially reduced efficiency. A SEER 13 air conditioning system that is installed poorly with leaky ductwork may operate at 25% to 40% lower efficiency during hot weather. Typical installation problems are:

- Improper charging of the system—the refrigerant of the cooling system is the workhorse—it flows back and forth between the inside coil and the outside coil, changing states, and undergoing compression and expansion. A system can have too little or too much refrigerant. The HVAC contractor should use the manufacturer’s installation procedures to charge the system properly. The correct charge cannot be ensured by pressure gauge measurements alone. In new construction, the refrigerant should be weighed in. Then, use either the supercharge temperature method or, for certain types of expansion valves, the subcooling method, to confirm that the charge is correct.
- Reduced air flow—if the system has poorly designed ductwork, constrictions in the air distribution system, clogged or more restrictive filters, or other impediments, the blower may not be able to transport adequate air over the indoor coils of the cooling system. Reduced air flow of 20% can drop the operating efficiency of the unit by about 1.7 SEER points; thus, a unit with a SEER 13.0 would only operate at SEER 11.3.
- Inadequate air flow to the outdoor unit—if the outdoor unit is located under a deck or within an enclosure, adequate air circulation between the unit and outdoor air may not occur. In such cases, the temperature of the air around the unit rises, thereby making it more difficult for the unit to cool the refrigerant that it is circulating. The efficiency of a unit surrounded by outdoor air that is 10 degrees warmer than the ambient outside temperature can be reduced by over 10%.

## HVAC SYSTEMS

For proper operation, a HVAC system must be properly designed, sized and installed. A proper HVAC system will provide an improved indoor environment and minimize the cost of operation. In the planning process for an energy efficient home, everything should be done to reduce the heating and cooling load on the home before the HVAC system is designed.

---

### SIZING

When considering a HVAC system for a residence, remember that energy efficient and passive solar homes have less demand for heating and cooling. Substantial savings may be obtained by installing smaller units that are properly sized to meet the load. Because energy bills in more efficient homes are lower, higher efficiency systems will not provide as much annual savings on energy bills and may not be as cost effective as in less efficient homes.

Not only does oversized equipment cost more, but also it can waste energy. Oversized equipment may also decrease comfort. For example, an oversized air conditioner cools a house but may not provide adequate dehumidification. This cool, but clammy air creates an uncomfortable environment.



***Do not rely on rule of thumb methods  
to size HVAC equipment.***

Many contractors select air conditioning systems based on a rule, such as 600 square feet of cooled area per ton of air conditioning (a ton provides 12,000 Btu per hour of cooling). Instead, use a sizing procedure such as:

- Calculations in Manual J published by the Air Conditioning Contractors Association;
- Similar procedures developed by the American Society of Heating, Refrigeration, and Air Conditioning Engineers (ASHRAE); or
- Software procedures developed by electric or gas utilities, the U.S. Department of Energy or HVAC equipment manufacturers.

The heating and cooling load calculations rely on the outside *winter and summer design temperatures* (see the appendix for a definition) and the size and type of construction for each component of the building envelope, as well as the heat given off by the lights, people, and equipment inside the house. If a zoned heating and cooling system is used, the loads in each zone should be calculated. Table 7-3 compares the size of heating and cooling systems for the homes in Table 2-2. The more efficient home reduces the heating load 35% and the cooling load 26%. Thus, the \$600 to \$1,000 savings from reducing the size of the HVAC equipment offset the additional cost of the energy features in the more efficient home.

<b>Table 7-3 Equipment Sizing Comparison</b>			
Type of House	Code Home HERS=98	ENERGY STAR® Home HERS=85	Exceeds ENERGY STAR® Home HERS=70
<b><i>HVAC System Sizing</i></b>			
Heating (BTU/hour)	52,200	38,800	25,700
Cooling (BTU/hour)	31,700	25,700	19,800
Estimated tons of cooling*	3.0	2.5	2.0
Square feet/ton	667	800	1,000
*Estimated at 110% of calculated size. There are 12,000 Btu/hour in a ton of cooling.			

Oversimplified rules-of-thumb would have provided an oversized heating and cooling system for the more efficient home. The typical rule-of-thumb in Kentucky has been to allow for 600 square feet per ton of air conditioning. Since the home has 2,000 square feet of conditioned space, HVAC contractors could well



provide 3.5 to 4 tons of cooling ( $2,000 \div 600 = 3.33$ , then round up.) The oversized unit would have cost more to install. In addition, the operating costs would be higher. The oversized unit would suffer greater wear and may not provide adequate dehumidification.

Proper sizing includes designing the cooling system to provide adequate dehumidification. In a mixed-humid climate, it is important to calculate the latent load. The latent load is the amount of dehumidification needed for the home. If the latent load is ignored, the home may become uncomfortable due to excess humidity.

The Sensible Heating Fraction (SHF) designates the portion of the cooling load for reducing indoor temperatures (sensible cooling). For example, in a HVAC unit with a 0.75 SHF, 75% of the energy expended by the unit goes to cool the temperature of indoor air. The remaining 25% goes for latent heat removal—taking moisture out of the air in the home. To accurately estimate the cooling load, the designer of a HVAC system must also calculate the desired SHF and thus, the latent load.

Many homes in Climate Zone 4 have design SHFs of approximately 0.7. This means that 70% of the cooling will be sensible and 30% latent. Systems that deliver less than 30% latent cooling may fail to provide adequate dehumidification in summer. It takes 15 minutes for most air conditioners to reach peak efficiency. During extreme outside temperatures (under 32°F in winter and over 88°F in summer), the system should run about 80% of the time. Oversized systems cool the home quickly and often never reach their peak operating efficiency.

---

## TEMPERATURE CONTROLS

The most basic type of control system is a heating and cooling thermostat. Programmable thermostats, also called setback thermostats, can be big energy savers for homes. These programmable thermostats automatically adjust the temperature setting when people are sleeping or are not at home. Be certain that the programmable thermostat selected is designed for the particular heating and cooling equipment it will be controlling. This is especially important for heat pumps, as an improper programmable thermostat can actually increase energy bills.

A thermostat should be located centrally within the house or zone. It should not receive direct sunlight or be near a heat-producing appliance. A good location is often 4 to 5 feet above the floor in an interior hallway near a return grille. The interior wall, on which it is installed, should be well sealed at the top and bottom to prevent circulation of cool air in winter or hot air in summer. Some homeowners have experienced discomfort and increased energy bills for years because air from the attic leaked into the wall cavity behind the thermostat and caused the cooling or heating system to run much longer than needed.

---

## ZONED HVAC SYSTEMS

Larger homes often use two or more separate heating and air conditioning units for different floors or areas. Multiple systems can maintain greater comfort throughout the house while saving energy by allowing different zones of the house to be at different temperatures. The greatest savings come when a unit serving an unoccupied zone can be turned off.





Rather than install two separate systems, HVAC contractors can provide automatic zoning systems that operate with one system. The ductwork in these systems typically has a series of thermostatically controlled dampers that regulate the flow of air to each zone. Although somewhat new in residential construction, thermostats, dampers, and controls for zoning large central systems have been used for years in commercial buildings.

If your heating and air conditioning subcontractors feel that installing two or three separate HVAC units is necessary, have them also estimate the cost of a single system with damper control over the ductwork. Such a system must be carefully designed to ensure that the blower is not damaged if dampers are closed to several supply ducts. In this situation, the blower still tries to deliver the same air flow as before, but now through only a few ducts. Back pressure created against the blades of the blower may cause damage to the motor. There are three primary design options:

1. Install a manufactured system that uses a dampered bypass duct connecting the supply plenum to the return ductwork. Installing the bypass damper is the typical approach. When only one zone is open, the bypass damper, which responds automatically to changes in pressure in the duct system, will open to allow some of the supply air to take a shortcut directly back to the return, thus decreasing the overall pressure in the ductwork (Figure 7-9).
2. Create two zones and oversize the ductwork so that when the damper to one zone is closed, the blower will not suffer damage. This approach is only recommended for two zones of approximately equal heating and cooling loads.
3. Use a variable speed HVAC system with a variable speed fan for the duct system. Because variable speed systems are usually more efficient than single-speed systems, they will further increase savings.

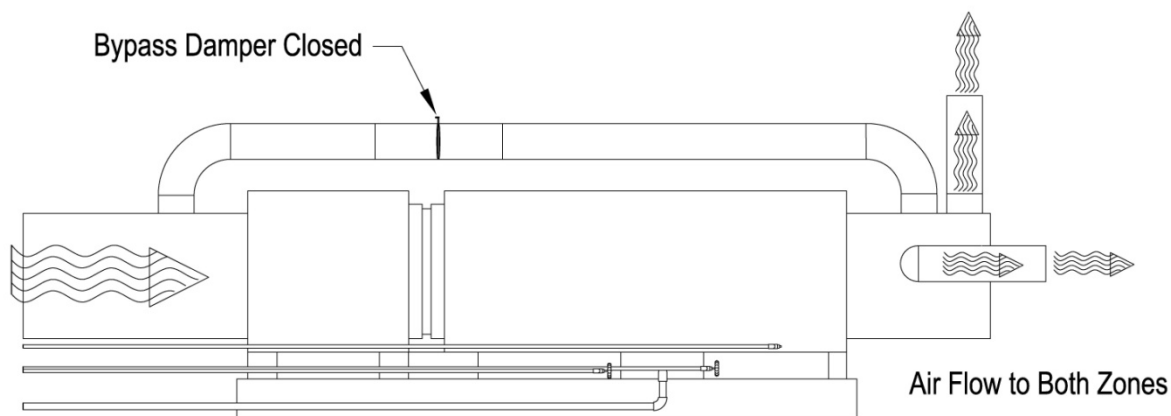

Figure 7 - 9 Automatic Zones System



## COOLING EQUIPMENT SELECTION

Tables 7-4 and 7-5 show equipment charts for two sample air conditioning units. Each system provides a wide range of outputs, depending on the blower speed and the temperature conditions. The SHF (Sensible Heating Fraction) is the fraction of the total output that cools down the air temperature. The remainder of the output dehumidifies the air and is the latent cooling. Note that both systems provide about 36,000 Btu/hour of cooling.

⇒ Consider System A (Table 7-4) with 80°F return air and SEER 15:

- At low fan speed, System A provides 35,800 Btu/hour, 0.71 SHF, and thus 29% latent cooling (dehumidification).
- At high fan speed, System A provides 38,800 Btu/hour, but a 0.81 SHF, and only 19% latent cooling. This is not enough dehumidification in many Kentucky homes.

<b>Table 7-4 Sample Cooling System A Data, SEER 15</b>				
<b>Total Air Volume (cfm)</b>	<b>Total Cooling Capacity (Btu/h)</b>	<b>Sensible Heating Fraction (SHF)</b>		
		<b>Dry Bulb (°F)</b>		
		<b>75°F</b>	<b>80°F</b>	<b>85°F</b>
950	35,800	0.58	0.71	0.84
1,200	37,500	0.61	0.76	0.91
1,450	38,800	0.64	0.81	0.96

⇒ Consider System B (Table 7-5) with 80°F return air and SEER 13:

- At low fan speed, System B provides 32,000 Btu/ hour, 0.67 SHF and 33% dehumidification.
- At high fan speed, System B provides 35,600 Btu/hour, 0.76 SHF and 24% dehumidification.

<b>Table 7-5 Sample Cooling System B Data, SEER 13</b>				
<b>Total Air Volume (cfm)</b>	<b>Total Cooling Capacity (Btu/h)</b>	<b>Sensible Heating Fraction (SHF)</b>		
		<b>Dry Bulb (°F)</b>		
		<b>75°F</b>	<b>80°F</b>	<b>85°F</b>
950	32,000	0.56	0.67	0.78
1,200	34,100	0.58	0.71	0.84
1,450	35,600	0.61	0.76	0.90

***Thus, System A, while nominally more efficient than B, provides less dehumidification and potentially less comfort.***



## VENTILATION AND INDOOR AIR QUALITY

All houses need ventilation to remove stale interior air and excessive moisture and to provide oxygen for the inhabitants. There has been considerable concern recently about how much ventilation is required to maintain the quality of air in homes. While it is difficult to gauge the severity of indoor air quality problems, building science experts and most indoor air quality specialists agree that the solution is not to build an inefficient, “leaky” home.

Research studies show that standard houses are as likely to have indoor air quality problems as energy efficient ones. While opening and closing windows offers one way to control outside air for ventilation, this strategy is rarely useful on a regular, year-round basis. Most building researchers believe that no house is so leaky that the occupants can be relieved of concerns about indoor air quality. The researchers recommend mechanical ventilation systems for all houses.

The amount of ventilation required depends on the number of occupants and their lifestyle, as well as the design of the home. The ANSI/ASHRAE standard, “Ventilation and Acceptable Indoor Air Quality in Low-Rise Residential Buildings” (ANSI/ASHRAE 62.2-2007) recommends that houses have 7.5 natural cubic feet per minute of fresh air per bedroom + 1, plus additional air flow equal to (in cubic feet per minute) 1% of the house conditioned area, measured in square feet. In addition, the standard requires exhaust fans in the kitchen and bathrooms that can be operated when needed.

For example, consider a 2,000 square foot home, with 3 bedrooms, and assume an occupancy of 4 people. The amount of ventilation recommended by ASHRAE would be 50 cfm:

$$7.5 \text{ cfm} \times (3 + 1) + 1\% \times 2,000 = 30 \text{ cfm} + 20 \text{ cfm} = 50 \text{ cfm}$$

Increasing the number of occupants or increasing the square footage of the home would increase the necessary ventilation requirements.

Older, drafty houses can have natural air leakage of 1.0 to 2.5 ACHnat. Standard homes built today are tighter and usually have rates of from 0.35 to 0.75 ACHnat. New, energy efficient homes have rates of 0.30 ACHnat or less. The problem is that air leaks are not a reliable source of fresh air and are not controllable.

The ENERGY STAR® rating system includes a consideration of homes that are tightly constructed. If the home has a measured natural air leakage rate below 0.35 ACHnat, the HERS score will not improve unless mechanical ventilation is provided. If the measured natural air leakage rate is below 0.25, the software will provide a warning that additional ventilation air should be provided and the amount needed.

Air leaks are unpredictable, and leakage rates for all houses vary. For example, air leakage is greater during cold, windy periods and can be quite low during hot weather. Thus, pollutants may accumulate during periods of calm weather even in drafty houses. These homes will also have many days when excessive infiltration provides too much ventilation, causing discomfort, high energy bills, and possible deterioration of the building envelope.

Concerns about indoor air quality are leading more and more homeowners to install controlled ventilation systems for providing a reliable source of fresh air. The simplest approach is to provide spot ventilation of bathrooms and kitchens to control moisture (see Figure 7-10). Nearly all exhaust fans in standard



construction are ineffective—a prime contributor to interior moisture problems in homes. Bath and kitchen exhaust fans should vent to the outside, not just into an attic or crawl space. General guidelines call for providing a minimum of 50 cubic feet per minute (cfm) of air flow for baths and 100 cfm for kitchens. Manufacturers should supply a cubic feet per minute (cfm) rating for any exhaust fan.

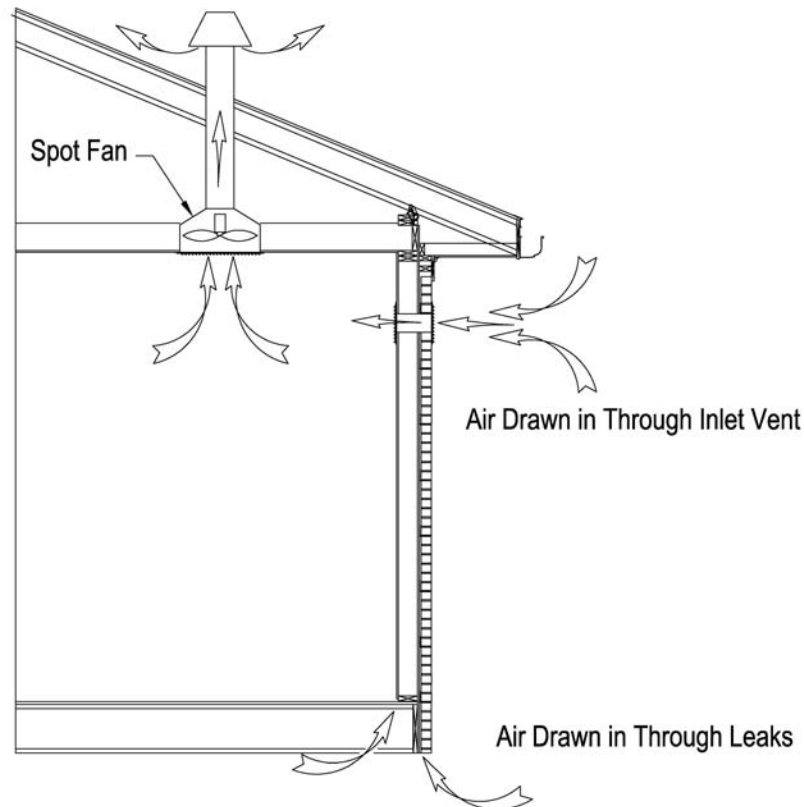

Figure 7-10 Ventilation with Spot Fan

The cubic feet per minute rating typically assumes the fan is working against an air pressure resistance of 0.1 inch of water column—the resistance provided by about 15 feet of straight, smooth metal duct. In practice, most fans are vented with flexible duct that provides much more resistance. Most fans are also rated at pressures of 0.25 to 0.30 inches of water column—the resistance found in most installations.

While ENERGY STAR® fans cost more, they are cheaper to operate and are usually better constructed and therefore, last longer and run quieter. The level of noise for a fan is measured in sones. Choose a fan with a sone rating of 2.0 or lower. Top quality models are often below 0.5 sones.

Many ceiling- or wall-mounted exhaust fans can be adapted as “in-line” blowers located outside of the living area, such as in an attic or basement. Manufacturers also offer in-line fans to vent a single bath or kitchen, or multiple rooms. Distancing the in-line fan, Figure 7-11, from the living area lessens noise problems.

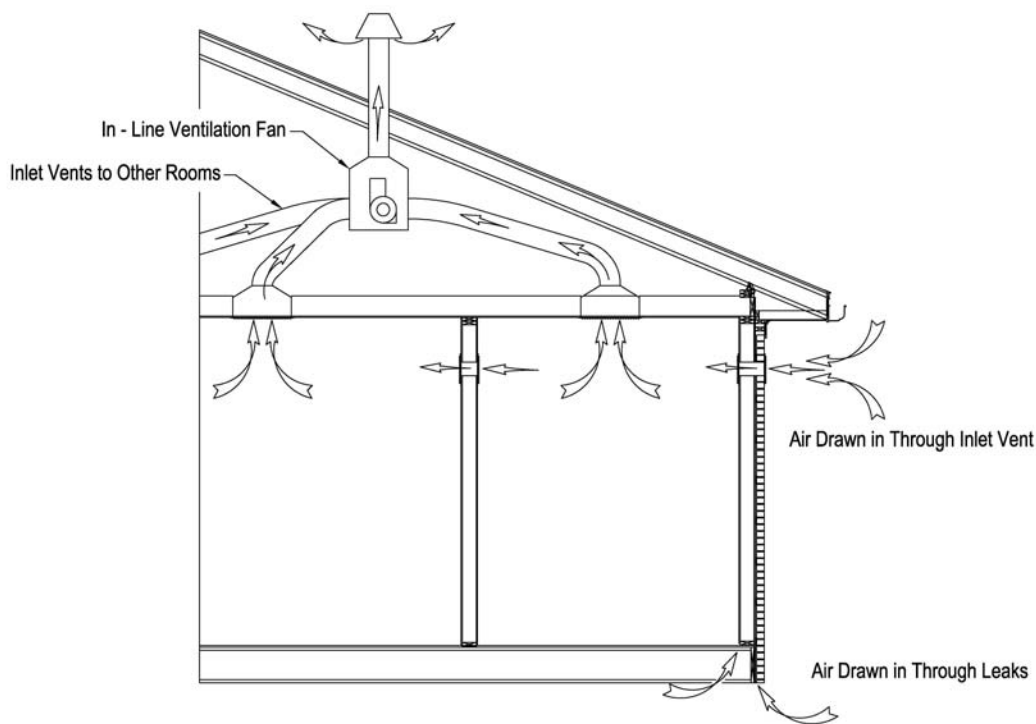

Figure 7-11 In-Line Ventilation with Spot Fan

While improving spot ventilation will certainly help control moisture problems, it may not provide adequate ventilation for the entire home. A whole house ventilation system can exhaust air from the kitchen, all baths, the main living area, and bedrooms.

Whole house ventilation systems usually have large single fans located in the attic or basement. Ductwork extends to rooms requiring ventilation. These units typically have two-speed motors. The low speed setting gives continuous ventilation—usually 10 cubic feet per minute per person or 0.35 ACH. The high speed setting can quickly vent moisture or odors.

## SUPPLYING OUTSIDE AIR FROM AIR LEAKS

The air vented from the home by exhaust fans must be replaced by outside air. This new air comes into the home either through air leakage or through a controlled inlet. Relying on air leaks requires no extra equipment; however, the occupant has little control over the air entry points. Many of the air leaks come from undesirable locations, such as crawl spaces or attics. If the home is airtight, the ventilation fans will not be able to pull in enough outside air to balance the air being exhausted. This generates a negative pressure in the home, which may cause increased wear on fan motors. In addition, the exhaust fans may threaten air quality by pulling exhaust gases from flues and chimneys back into the home.



---

## SUPPLYING OUTSIDE AIR FROM INLET VENTS

Providing fresh outside air through inlet vents is another option. These vents can often be purchased from energy specialty outlets by mail order. They are usually located in exterior walls. The amount of air they allow into the home can be controlled manually or by humidity sensors. Locate inlet vents where they will not create uncomfortable drafts. These inlet vents are often installed in bedroom closets with louvered doors or high on exterior walls.

---

## SUPPLYING OUTSIDE AIR VIA DUCTED MAKE-UP AIR

Outside air can also be drawn into and distributed through the home via the ducts for a forced-air heating and cooling system. This type of system usually has an automatically controlled outside air damper in the return duct system.

The blower for the ventilation system is either the air handler for the heating and cooling system or a smaller unit that is strictly designed to provide ventilation air. A slight disadvantage of using the HVAC blower is that incoming ventilation air may have sufficient velocity to affect comfort during cold weather.

The return ductwork for the heating and cooling system may be connected to a small outside air duct that has a damper which opens when the ventilation fan operates. The incoming air flow should not adversely affect comfort. Special controls are available to ensure that the air handler runs a certain percentage of every hour, thus providing fresh air on a regular basis.

---

## DEHUMIDIFICATION-VENTILATION SYSTEMS

Kentucky homes are often more humid than desired. A combined dehumidification-ventilation system can bring in fresh (but humid outdoor air), remove moisture, and supply it to the home (see Figure 7-12). These systems can also filter incoming air. These systems require an additional mechanical device. A dehumidifier must be installed on the air supply duct. This dehumidifier should be designed for the specific needs of the home.

A well-designed conventional A/C system without outdoor ventilation air should not need supplemental dehumidification. It is the excess moisture in outdoor ventilation air that may require the special dehumidification equipment, especially when mild outdoor temperatures do not require the cooling system to operate many hours per day to maintain the setpoint temperature.

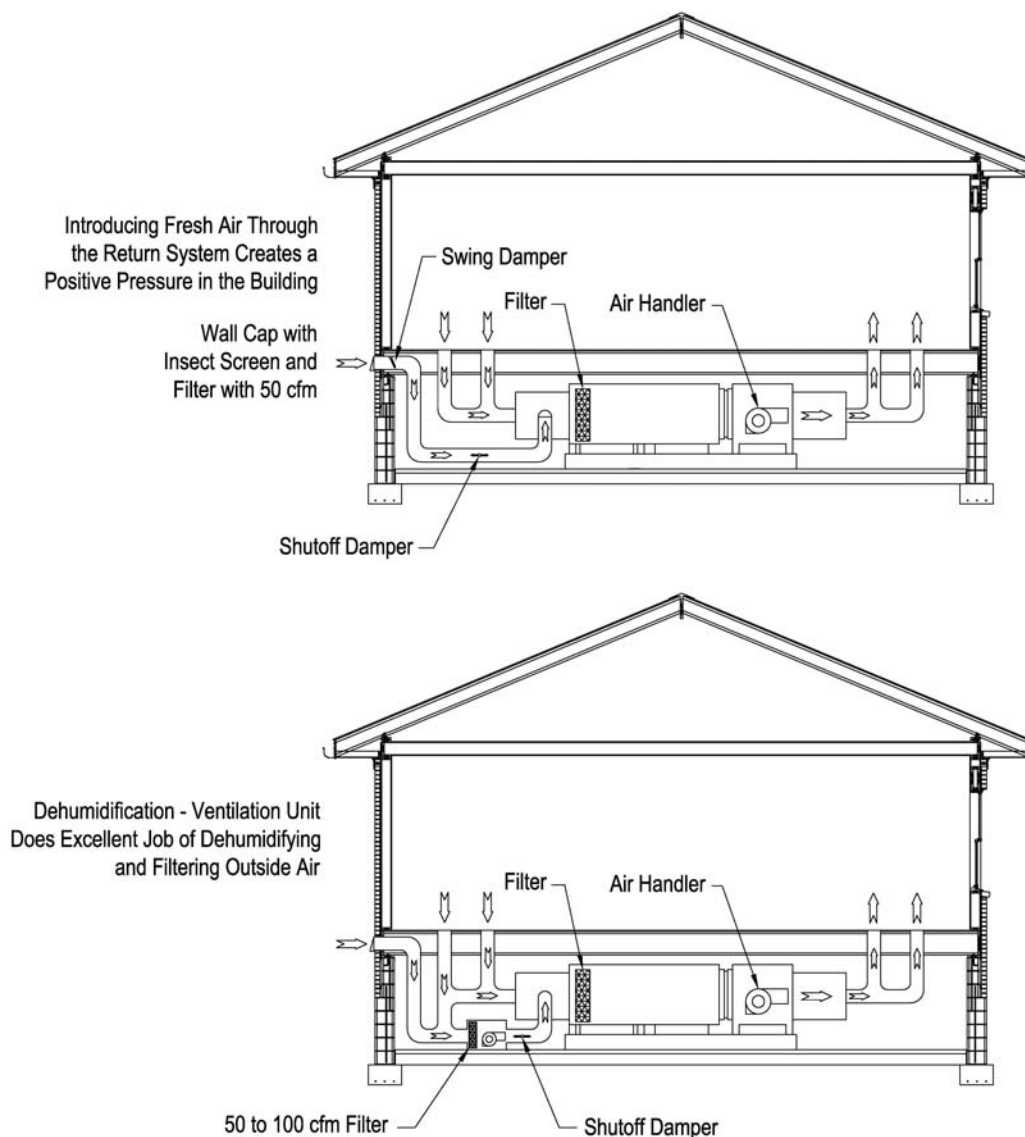

Figure 7-12 Fresh Air and Dehumidification Strategies

## HEAT RECOVERY VENTILATORS

Air-to-air heat exchangers, or heat recovery ventilators (HRV), typically have separate duct systems that draw in outside air for ventilation and distribute fresh air throughout the house. Winter heat from stale room air is “exchanged” for the cooler incoming air. Some models, called enthalpy heat exchangers, can also recapture cooling energy in summer by exchanging moisture between exhaust and supply air.

While energy experts have questioned the value of the heat saved in Kentucky homes for the \$400 to \$1,500 cost for an HRV, recent studies on enthalpy units indicate their dehumidification benefit in

summer offers an advantage over ventilation-only systems. The value of any heat recovery ventilation system should not be determined solely on the cost of recovered energy. The controlled ventilation and improved quality of the indoor environment must be considered as well.

## SAMPLE VENTILATION PLANS

Three options for providing a mechanical ventilation system for a home are shown in the following designs. While providing mechanical ventilation plans is routine for commercial buildings, their use in homes is just beginning. As a result, few standard designs exist and some time will be needed for them to be developed for different climates.

### DESIGN 1: UPGRADED SPOT EXHAUST VENTILATION

This relatively simple and inexpensive whole house ventilation system, Figure 7-13, integrates spot ventilation using bathroom and kitchen exhaust fans with an upgraded exhaust fan (usually 100 to 150 cfm) in a centrally located bathroom. When the fan operates, outside air is drawn through inlets in closets with louvered doors. A timer, set to provide ventilation at regular intervals, controls the fan. Interior doors are undercut to allow air flow to the central exhaust fan. The fan must be a long-life, high-quality unit that operates quietly. In addition to the automatic ventilation provided by this system, occupants can turn on all exhaust fans manually as needed.

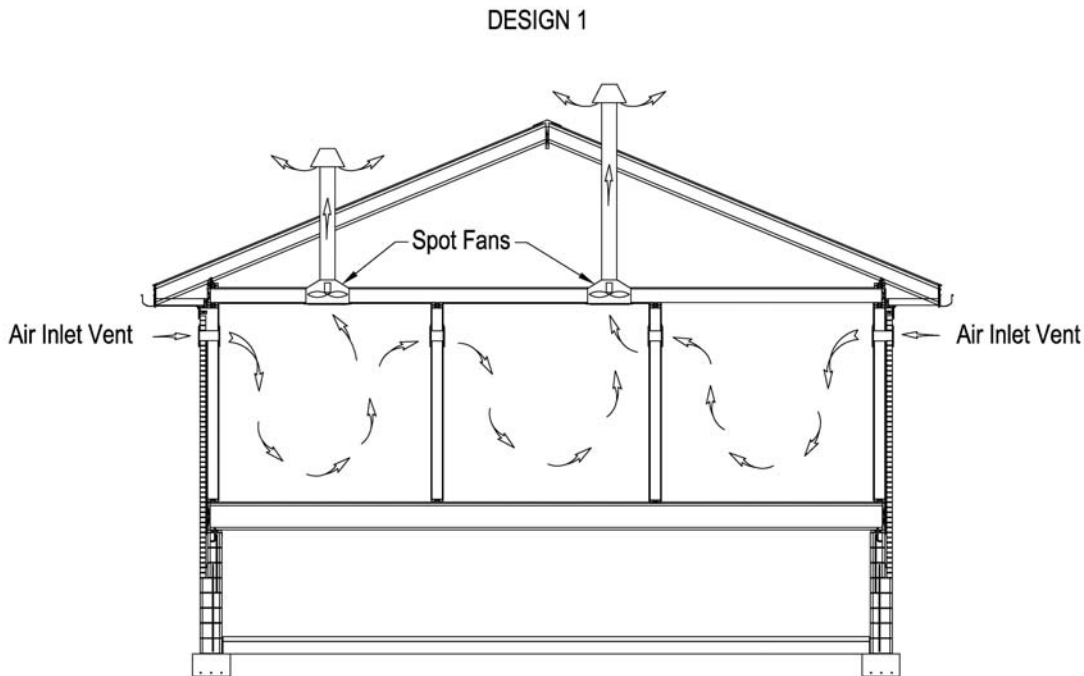

Figure 7-13 Upgraded Spot Exhaust Ventilation



## DESIGN 2: WHOLE HOUSE VENTILATION SYSTEM

This whole house ventilation system uses a centralized two-speed exhaust fan to draw air from the kitchen, bath, laundry, and living areas. A timer controls the blower. The system should provide approximately 0.35 natural air changes per hour (ACHnat) on low speed and 1.0 ACHnat on high speed. A separate dampered duct connected to the return air system supplies outside air. When the exhaust fan operates, Figure 7-14, the outside air damper opens and allows air to be drawn into the house through the forced-air ductwork.

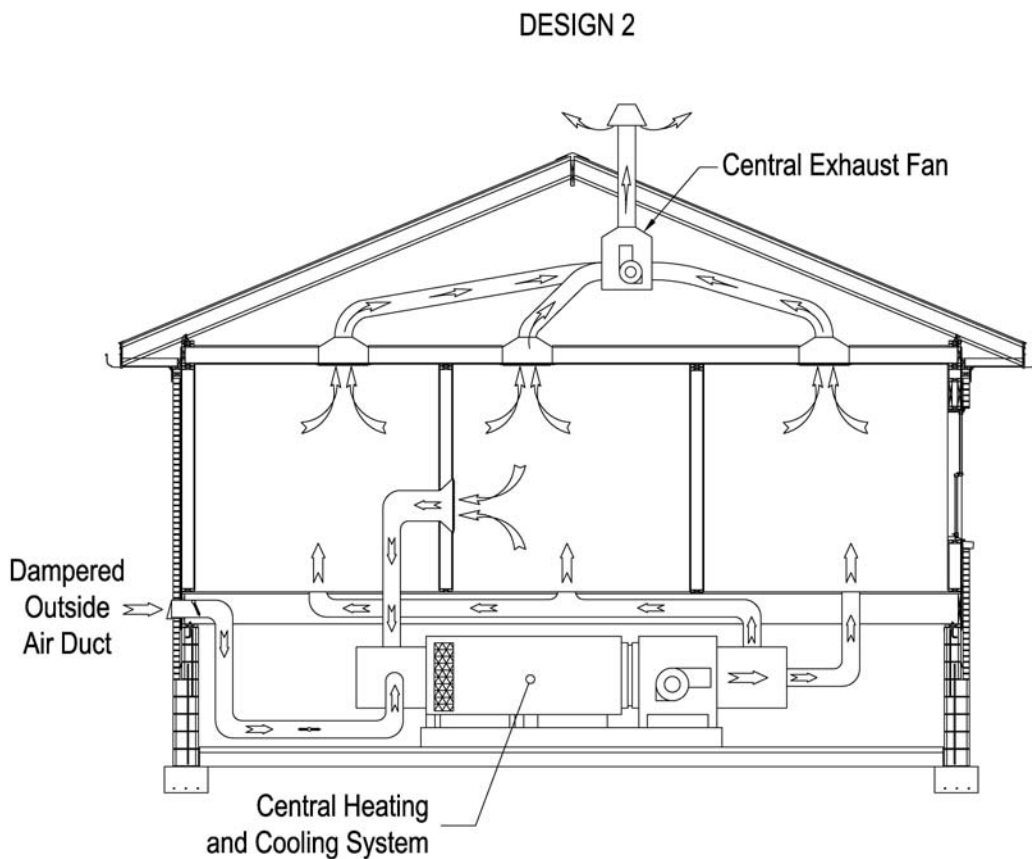

Figure 7-14 Whole House Ventilation System

### DESIGN 3: HEAT RECOVERY VENTILATION (HRV) SYSTEM

An enthalpy recovery ventilator draws fresh outside air through a duct into the heat exchange equipment and recaptures heating or cooling energy from stale room air as it is being exhausted (see Figure 7-15). The system also dries incoming humid air in summer. This is a particular benefit in the Southeast. Fresh air flows into the house via a separate duct system, which should be sealed as tightly as the HVAC ductwork. Room air can either be ducted to the exchanger from several rooms or to a single source. Some HRV units can be wall-mounted in the living area, while others are designed for utility rooms or basements.

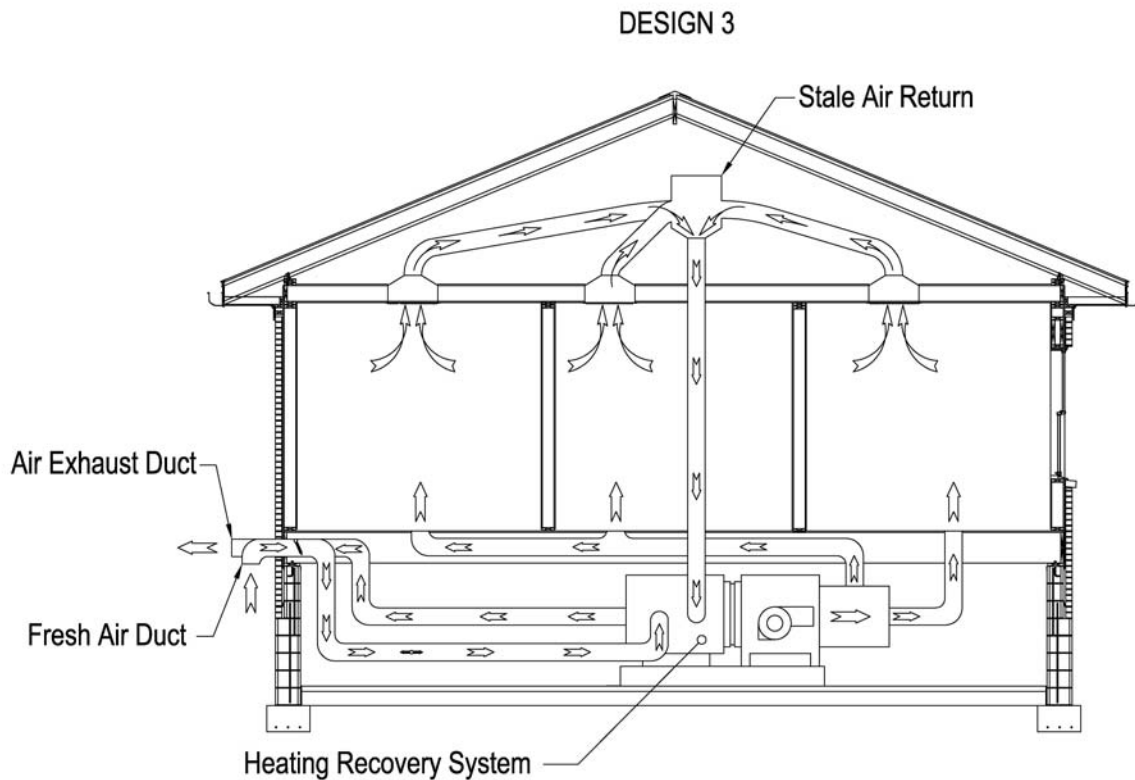

Figure 7-15 Heat Recovery Ventilation (HRV) System

## RADON

Radon is a cancer-causing, radioactive gas that is found in soils throughout the United States. Although you cannot see, smell or taste radon, it can become concentrated at dangerous levels in any building, including homes, offices, and schools. People are most likely to get the greatest exposure at home because most time is spent there.

### REMOVING RADON

Ventilating under the foundation will help remove radon and other soil gases, such as moisture vapor, before they have a chance to enter the home. It is more cost-effective to include any radon resistant techniques while building a home, rather than retrofitting an existing home. A typical installation during construction will cost the homeowner roughly \$50 to \$300, whereas retrofitting an existing home can cost up to \$2,000. In addition, no operating costs are associated with this passively vented system. If elevated radon levels are found in the home, a fan can be added to make an active system.

Figure 7-16 shows the basics of radon resistant construction for crawl spaces and slabs/basement foundation types.

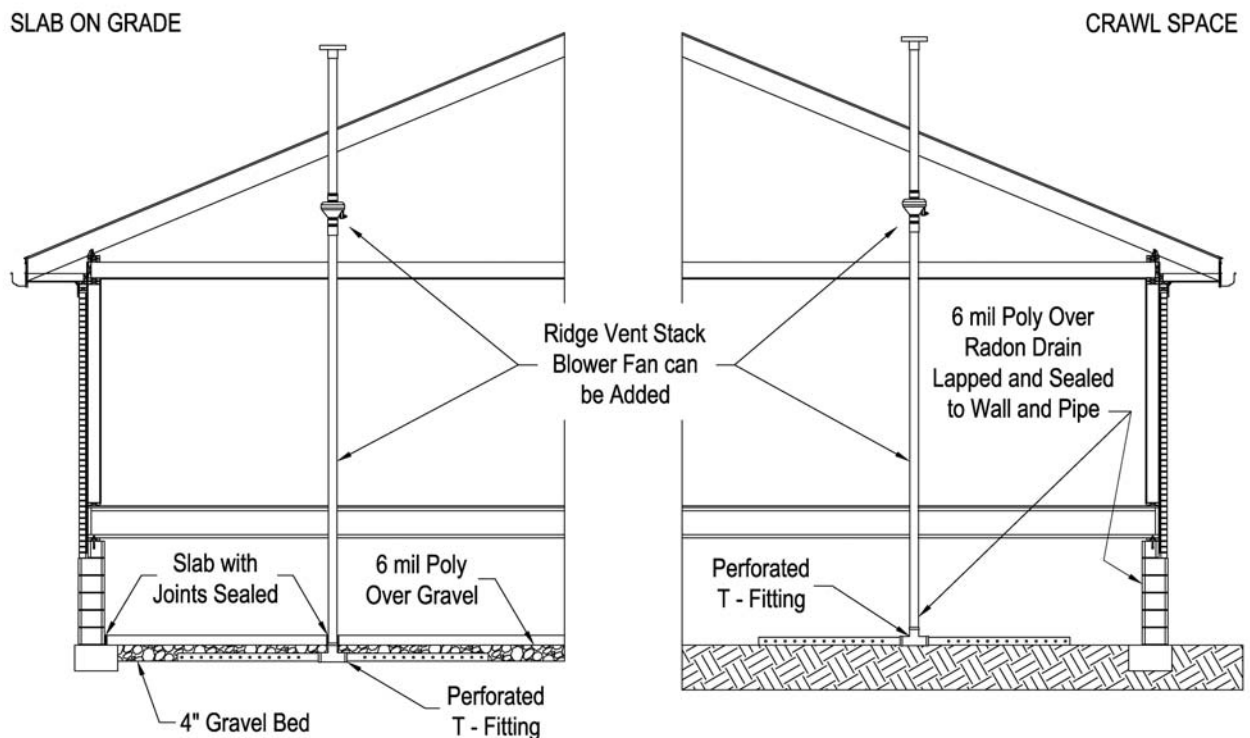

Figure 7-16 Radon Resistant Construction



## PASSIVE AND ACTIVE RADON RESISTANT CONSTRUCTION

---

*Passive concept:* a perforated “T” fitting is attached to a vertical plastic vent stack that penetrates the roof. The “T” is buried in the gravel under the foundation slab and gases can slowly percolate through the “T” and out the stack.

*Active concept:* if unacceptable levels of radon are still present, after checking the radon levels from a passive system, a fan can be added to generate suction to pull gases out through the stack.

### SLAB-ON-GRADE OR BASEMENT

- Use a 4 to 6 inch gravel base.
- Install continuous layer of 6-mil polyethylene.
- Stub in “T” below polyethylene that protrudes through polyethylene and extends above poured floor height.
- Pour slab or basement floor.
- Seal slab joints with caulk.

### CRAWL SPACE

- Install sealed, continuous layer of 6-mil polyethylene.
- Install “T” below polyethylene that protrudes through polyethylene.

### ALL FOUNDATIONS

- Install a vertical 3-inch PVC pipe from the foundation to the roof through an interior wall.
- Connect the “T” to the vertical 3-inch PVC pipe for passive mitigation.
- Have electrician stub-in junction box in attic.
- Label PVC pipe “RADON” so that future plumbing work will not be tied into the stack.

## TESTING FOR RADON

---

After building a radon resistant home, it is still recommended to test the home for elevated radon levels. Low-cost “do-it-yourself” radon test kits can be obtained through the mail, in hardware stores, and other retail outlets, and possibly from your local government. If desired, a trained contractor can be hired to do the testing. Make certain that the contractor is certified by the National Environmental Health Association (NEHA).

## WHAT IF HIGH LEVELS ARE FOUND?

---

With the basics of a radon mitigation system already installed, it is relatively inexpensive and easy to make the system active. Adding an in-line fan, rated for continuous operation, is a relatively simple addition that will ensure the safe removal of radon from beneath the home.